

5800 Series

Materials Testing Systems for the Most Demanding Applications



Testing from A to Z

Instron® systems engineered to meet your testing needs

Instron's electromechanical testing systems are engineered to provide our customers with the most comprehensive and effective solutions for their materials testing challenges. Instron systems are used worldwide by industrial designers, manufacturing engineers and scientists in research labs, universities and on the production floor. We deliver the power and flexibility that allows you to accurately evaluate the properties of new materials, components and devices.

Our 3-tier solution allows us to meet all your requirements and testing needs. For basic pass/fail requirements or straightforward testing, the affordable 3300 Series could be for you. To meet high-level quality control and research and development applications requirements, the 5500 Series is the ideal choice. For the ultimate in testing capability, the 5800 Series delivers a level of flexibility and power not available in any other Instron electromechanical test system.

Instron has built a reputation on understanding the widest array of application problems in order to provide the best possible solution for your testing needs. You'll be testing faster-with greater accuracy-with a system tailored to the specific requirements of your application.

Take advantage of sixty years of worldwide materials testing experience. Instron provides a level of data integrity, security and a value unmatched in the industry - delivering results that you and your customers can depend on.

5800 Series

The gold standard for advanced materials testing, with capabilities and performance unmatched in the industry.



5500 Series

A versatile, robust system for a wide variety of testing applications - only Instron would classify the feature-rich 5500 as a "midrange" system.



3300 Series

A highly affordable unit with the accuracy and flexibility normally found only in much more expensive testing systems.



The 5800 Series:

Advanced materials testing solutions

The 5800 Series isn't just about unique technical performance and application coverage; 5800 Series also represents excellence in human factors engineering, which focuses heavily on convenience, safety and simplicity of maintenance. From the storage areas on each frame to the clear digital displays, users will appreciate the superb attention to detail Instron® is famous for.



▲ Instron MicroTester frame in horizontal orientation.

5800 Premier Features

Customer Benefits

Applications Versatility

- The 5800's flexible user interface puts the power and control with you – the user. There are no boundaries with 5800.

Instills user confidence and assurance that Instron has the ability to deliver a solution to meet unique testing requirements.

LabVIEW

- Highly intuitive graphical programming environment streamlines application development by allowing you to program the 5800
- 5800 Series open architecture allows you to develop custom applications to meet unique needs.

Develop complex testing sequences beyond the scope of standard software packages. LabView software drivers allow you to design your own front end, define the interface to the electronics and hardware or even create your own specific application.

Advanced Electronics

- 5 KHz data acquisition to capture transient events
- Adjustable bandwidth ranging from 1 Hz to 1000 Hz
- 5 KHz control loop update rate is 10 times faster than conventional systems

A brittle specimen breaks very quickly. To capture the event, ultra-high data acquisition provides repeatable and reliable results.

Powerful Test Control

- Auto-tuning feature provides more stable control
- Wide range of waveshape options, such as sine, ramp and trapezoid can be applied to test specimens
- Amplitude control minimizes risk of undershooting

By defining the waveform you are able to replicate real-life testing conditions, such as running or walking.

Flexible User Interface

- The 5800 Software Console performs traditional hardware functions in a flexible interface
- Optional Touch Screen operator panel allows user to calibrate transducers, setup and run tests, etc. by pressing buttons on touch-sensitive monitor

Select the user interface that matches the needs and requirements of your test environment—ensuring maximum operator productivity, ease of use and ergonomic excellence.

Powerful Software Suites

- Bluehill® software for static and cyclic tests
- FastTrack™ for complex sequence loading applications

Select the software suite that best suits your needs. Software choices are available that not only combine power and ease of use, but meet wide range of standard and specialized testing applications.

Rugged, Versatile Load Frames

- Pre-loaded ball screws, heavy duty bearings and robust guidance columns

Built to withstand years of high volume, high force testing and provides years of reliable use with minimal downtime.

Full Applications Versatility

5800 Series versatility is designed into each element of the testing system. All 5800 Series systems use an advanced DSP technology controller to provide unparalleled test control and data acquisition. The 5800 controller provides the best combination of accuracy, resolution and bandwidth for data acquisition available. In addition, test control performance and flexibility in executing complex commands is unmatched.

Load frame capacities are available from 500 N to 600 kN, allowing you to select the right size system for your needs. Specialty load frames such as the 5848 MicroTester provide nanometer range motion control for microelectronics, nanomaterials and biomedical applications.

Software choices such as Bluehill® and FastTrack™ provide ready-to-use applications for common tests. LabVIEW drivers allow the 5800 to interface with one of the most popular laboratory instrumentation software packages available allowing the user to create custom applications for non-standard test control. And Instron®'s Touch Screen Operator Panel Software provides an alternative user interface and simple operation for monotonic or cyclic tests.

Integrated accessories such as the Advanced Video Extensometer (AVE) provide state-of-the-art measurement capabilities. A large range of grips and fixtures is available to work with your test specimens.



▲ Instron's Advanced Video Extensometer (AVE) is fully integrated with 5800 Series Systems.

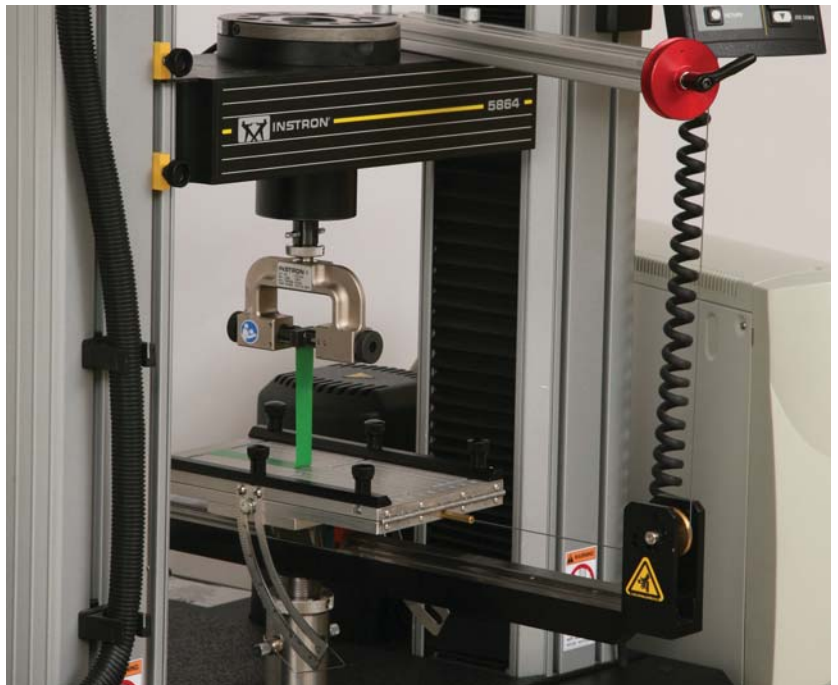

▲ 5800 Series high-speed data capture and bandwidth provide more detail in peel test results.

User Programmability with LabVIEW

A world of possibilities - a power-user's dream

The 5800 Series, available with 32-bit LabVIEW software drivers, provides a level of user programmability that's unique in the industry. LabVIEW is a graphical programming environment from National Instruments for acquiring, analyzing and displaying data from a broad range of laboratory instruments. It's recognized as the industry standard and is the tool of choice in many test labs.

Rather than writing traditional software code, LabVIEW follows a highly intuitive graphical process that streamlines application development. The ability to freely program the 5800 system using LabVIEW creates endless testing possibilities, from the simplest to the most complex. You can design your own front end to meet a unique application need, define your interface to the electronics and hardware or create very specific applications to match your testing requirements.

LabVIEW provides a high-level graphical programming environment for the HS488 high performance, industry-standard GPIB interface to the command set of the 5800 controller. HS488 was developed by National Instruments to increase the maximum data transfer rate of the ANSI/IEEE Standard 488.1-1987 by up to 8 MB per second. Together, the GPIB interface and LabVIEW allow the development of complex testing sequences beyond the scope of standard software packages.

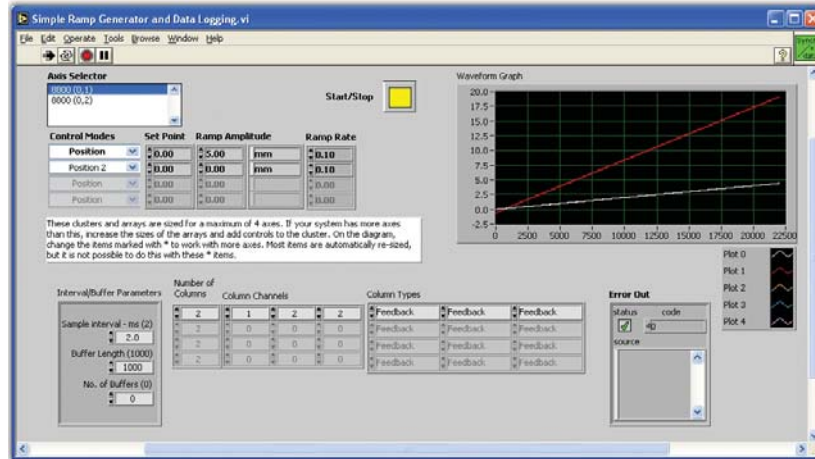

▲ Front panel of the example program 'Simple Ramp Generator and Data Logging.vi'.

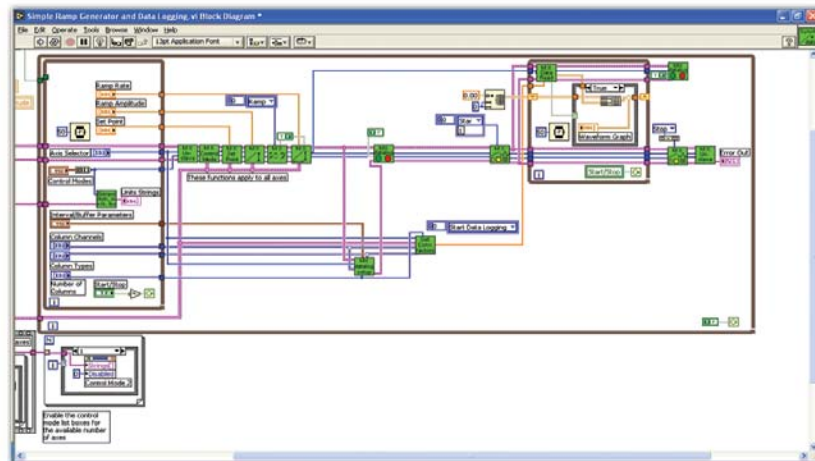

▲ The code or diagram of the above example program, showing the Instron® drivers connected together to produce a working program.

Most Advanced Electronics

The 5800 controller incorporates many unique features to provide the highest available accuracy, resolution and response. It's the ultimate in materials testing electronics – delivering power and flexibility when you need it most.

Up to 5 KHz Data Acquisition

The advanced digital design allows synchronous data capture on all channels – up to 5 kHz. This means much greater accuracy and fidelity when evaluating high-speed events, such as cracking in composite materials or in applications where loads change rapidly such as peel/tear tests. The ability to capture data at high acquisition rates means that more information can be recorded about the test specimen to better characterize the material or component.

Exceptional Accuracy Over a Wide Range

The 5800 provides 0.4% accuracy to 1/100 and 0.5% accuracy to 1/500 – better than any other materials testing machine on the market. This means better data and test control from the beginning of the test to the end and less requirement for changing load cells for low-force applications.

5 KHz Control Loop Update Rate

This is faster than conventional systems, dramatically improving the ability of the load frame to follow the demand signal. The high-update rate is especially beneficial when testing in load or strain control, where specimen motion controls the crosshead directly. It improves the fidelity with which complex demand waveforms can be followed, as well as improves test control at or around fracture.



▲ 5800 Series incorporates a high performance materials testing system controller combining ultra-high data and control-loop update rates with flexible and accessible test functionality.

Adjustable Bandwidth

The 5800 bandwidth can be adjusted from 1 Hz to 100 Hz via the controller to best suit the test application. The default bandwidth is 10 Hz, which is considered a good compromise between response and noise prevention. But the 5800 gives you the freedom to select a lower bandwidth to minimize noise or a higher bandwidth to capture fast events. This ability to define small changes within the signal range allows you to detect very sensitive characteristics of the material.

Superior Resolution

High-resolution feedback sampling and signal conditioning technology brings data quality to a new level for digital servo controllers. Sensor conditioning provide 19-bit resolution over the entire full-scale of the position, load and strain transducers.

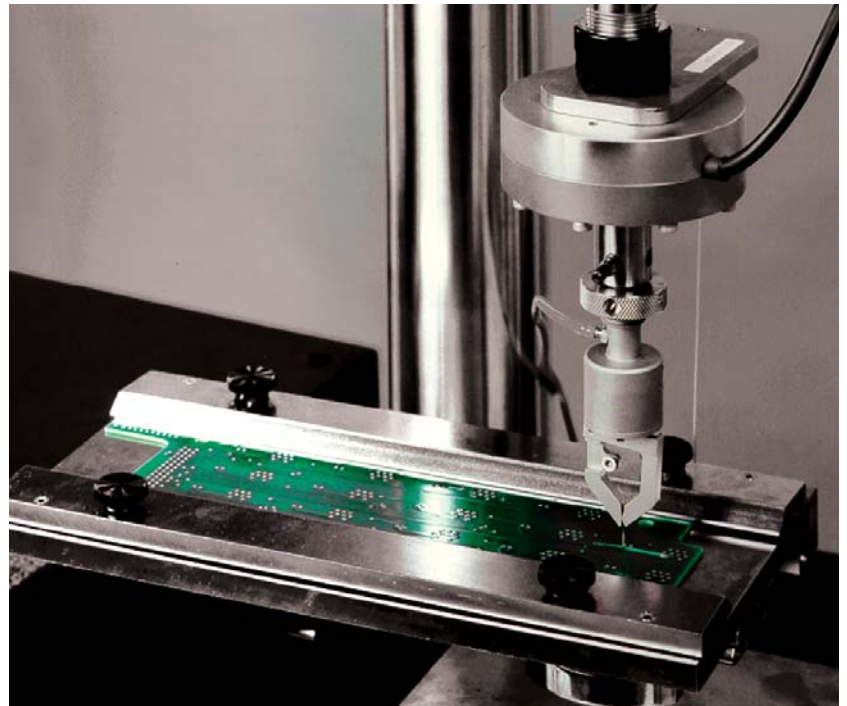

▲ Miniature 90° constant angle peel fixture (2820-034) performing peel test on printed circuit board.

Most Powerful Test Control

The 5800 provides the sophisticated user with many powerful control features to support complex testing.

Definable Waveforms

This powerful feature allows a wide range of waveshape options to be applied to specimens and components. You can specify sine, triangle, sawtooth, trapezoid, square, ramp, block, random waveforms – or define your own.

For example, when evaluating running shoes, a test may involve placing a pressure sensor on an individual's foot and observing the change in material properties when walking or running. The ability to create a distinctive cycle that replicates what is happening in real life – in this case, the test subject's natural gait – allows more representative, realistic and accurate testing.

Automatic Loop Shaping

Access to Proportional (P), Integral (I), Derivative (D), and Lag (L) control parameters dramatically improves tuning capabilities compared to conventional systems, which only feature the proportional term. The Lag (L) term is especially beneficial when using strain control on extensometers with low resonant frequencies (e.g. those with long arms). In practice, this means you get better, more stable control over a wider range of applications.

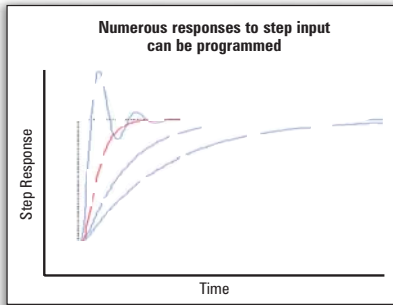

▲ Automatic loop shaping optimizes the control-loop parameters of the test system at the press of a button.

Amplitude Control

The relatively high inertia of an electromechanical drive system means that you may experience undershoot if running cyclic waveforms at certain frequencies or amplitudes. Amplitude Control compares the demanded value with the actual value and automatically adjusts the demand to minimize undershooting of the peaks.

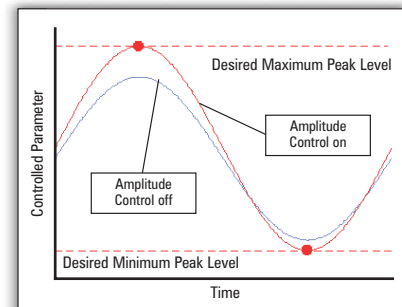

▲ 5800 Series has a built-in facility to maintain the amplitude requested for tests as the compliance of a test piece changes.



▲ Every 5800 Series system provides the highest possible data integrity and flexibility to meet a diverse range of testing applications.

Most Flexible User Interface

The 5800 Series provides the ultimate in real-time test control, setup and post-test operations. The control panel and flexible software console ensure operator productivity and ease of use, even for the most demanding applications.

5800 Software Console

The 5800 software console performs traditional hardware functions in a flexible interface for more advanced testing. The control panel displays real-time data and hardware status while serving as a “home base” for setting up system parameters, transducers and live displays. The console can also be used to perform basic ramp loading and acquire data for subsequent analysis by exporting it to user-supplied third party software, such as Microsoft® Excel.

- Reduction of color on the screen keeps eye fatigue to a minimum.
- Combines the best attributes of the control panel and screen display to provide a better user interface.

5800 Control Panel

Conveniently mounted on the load frame, the control panel provides instant access to the most widely-used materials testing functions, including start and stop, balance load, reset gauge length and jog. The fine-position rotary thumbwheel is particularly useful for accurate setting of the initial crosshead position. The Specimen Protect feature safeguards against accidental overloading of specimens.

- Ergonomics are important too, which is why the control panel is located near the test area and is height-adjustable.
- Control panel buttons are designed with tactile and visual feedback, using a size and spacing that reduces errant keystrokes.

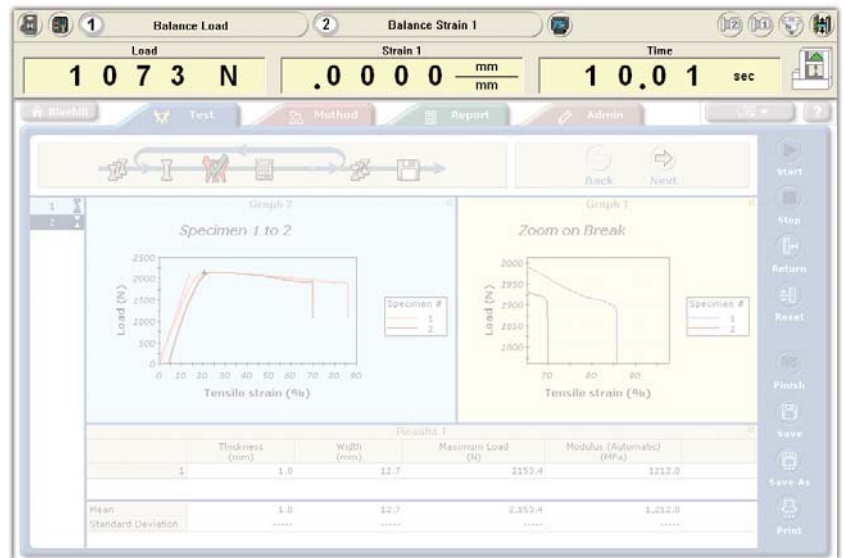

▲ Runtime screen for 'Prompted Test'



▲ The 5800 Series control panel is designed to work with the 5800 Console to provide a friendly, flexible user interface. Conveniently mounted on the load frame, this panel provides all the controls you need to run tests.

Touch Screen Operator Panel

The full-screen touch panel brings a new level of user convenience to materials testing. The touch screen software allows the user to calibrate transducers, setup and run tests, display transducer values, graph the results and save the test data to a file by pressing buttons on a touch-sensitive computer monitor. The touch buttons streamline user interaction with the system – there's no need to use any other screen or operator console.

Test Control - the panel allows the user to select either waveform control or a ramp tool. The waveform control allows the operator to run cyclic or ramp waveforms using the 'Start', 'Hold', 'Finish' and 'Reset' buttons. The ramp tool allows the operator to setup predefined ramp rates for each controllable transducer. 'Up/Down' buttons can be pressed to move the crosshead up or down at the specified rate.

The Scope Tool - allows the operator to select up to four channels of data to be shown on a real-time graphical display. The graphical display can operate in three modes, which can emulate, either: an XY Graph, an oscilloscope or a scrolling chart recorder. The graphical display is normally set to a small size, allowing direct access to the various control buttons. However, it can be expanded to a larger size allowing for detailed viewing of test data.



▲ Ramp tool expanded graph

Software for all Testing Needs...

The 5800 Series is available with two software suites that combine power and ease of use for a wide range of standard and specialized tests:

- Bluehill® – a fully-integrated modular package that provides easy, tailored application solutions for static and cyclic tests.
- FastTrack™ – a suite of advanced sequence loading applications such as K_{IC} , J_{IC} and block/sequential programming.

Bluehill

Bluehill provides the most powerful and flexible materials testing package available along with an intuitive web-like design that users at all levels will find easy to learn and use. From the simplicity of a basic peak load test to the power required for a complex cyclic test, users will appreciate the minimum learning and training required.

Bluehill's tabbed user interface consolidates testing, test method definition, test reports and system administration, making the entire testing process very easy to manage. Parameters such as fixture setup, test terminology, unit choices and calculations are configured automatically, allowing your laboratory to achieve maximum productivity quickly and easily.



The FastTrack suite of application programs for 5800 Series includes:

- Fracture toughness (K_{IC})
- Unloading Compliance (J_{IC})
- SAX™/WaveMaker™ for more advanced cyclic and user-defined loading profiles
- LabVIEW drivers allow the user complete freedom to write custom programs using National Instruments LabVIEW products

Simple Cyclic - SAX

Capabilities include constant amplitude cycles with standard and user-defined wave shapes, periodic data acquisition, DDE, live digital displays and up to four real-time graphs.

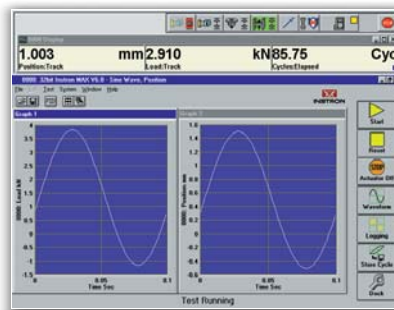

K_{IC} and CTOD Fracture Toughness

Performs in accordance with ASTM E 399 and BS7448 for tests on low to medium toughness specimens. Includes full analysis and validity checking.

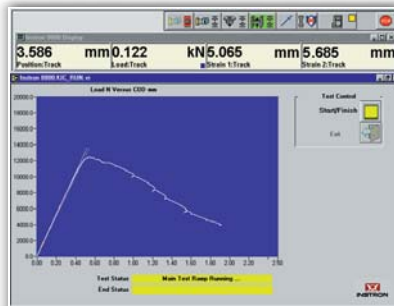

Write Your Own Program – LabVIEW Drivers

Provides tools for programming 5800 in the LabVIEW graphical programming environment. Includes control, data acquisition and example programs.

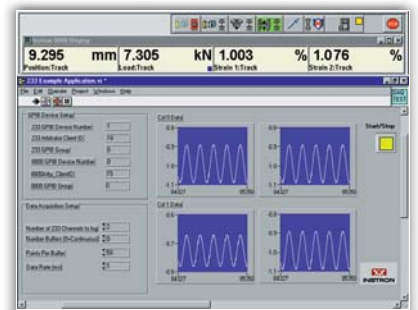

Advanced Cyclic – WaveMaker

Capabilities include block loading with a variety of control mode changes, absolute or relative ramps, sines and other wave shapes. Data can be acquired continuously or periodically throughout the test sequence.

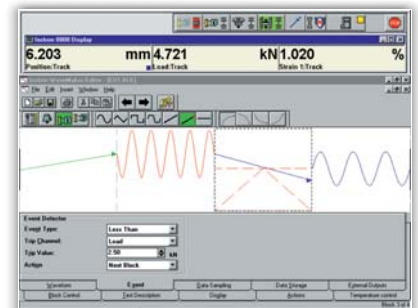

J-Integral Fracture Toughness

Performs in accordance with ASTM E 813 for single specimen J_{IC} and J-Integral tests on high toughness or small specimens. Includes full analysis and validity checking.

Specialty Applications and Systems

Instron® offers systems for a wide variety of specific applications. From biomaterials and biomedical devices to microelectronics, the 5800 Series offers solutions for demanding tests.

Biomedical

Longer life expectancy, an increasingly active population and scientific advances fuel demand for new and improved devices and materials. Instron solutions are designed to evaluate material properties, subsequently advancing the understanding of physical properties and performances of many medical products and materials.

Stents are used to support the arterial walls after angioplasty and are typically made of nitinol wire. The non-contacting AVE is the preferred method for strain measurement due to its higher accuracy and resolution. It is especially beneficial when the specimen under test cannot support the weight of a traditional clip on extensometer, as in the case of soft tissues or nitinol.



▲ Cord and yarn grips and AVE non-contacting video extensometer testing nitinol wire

Microelectronics

For applications involving small specimens and very precise displacements, the Instron MicroTester provides the full functionality of the 5800 controller electronics. Designed for both static and dynamic testing, the MicroTester can perform tensile, compression, flex, cycle and shear tests on a variety of materials, specimens and components.

System Features

- 2 kN maximum force (static)
- Unobstructed workspace
- Stiff reaction frame for accurate and repeatable testing
- Versatile horizontal or vertical positioning
- High-precision drive system
- Nano-level accuracy position measurement system
- Fatigue rated to 400 N maximum force
- No need for air or hydraulic supply



▲ Solder ball shear test



▲ 5848 Microtester with Environmental Chamber for non-ambient temperature testing

Robust Frame Designs

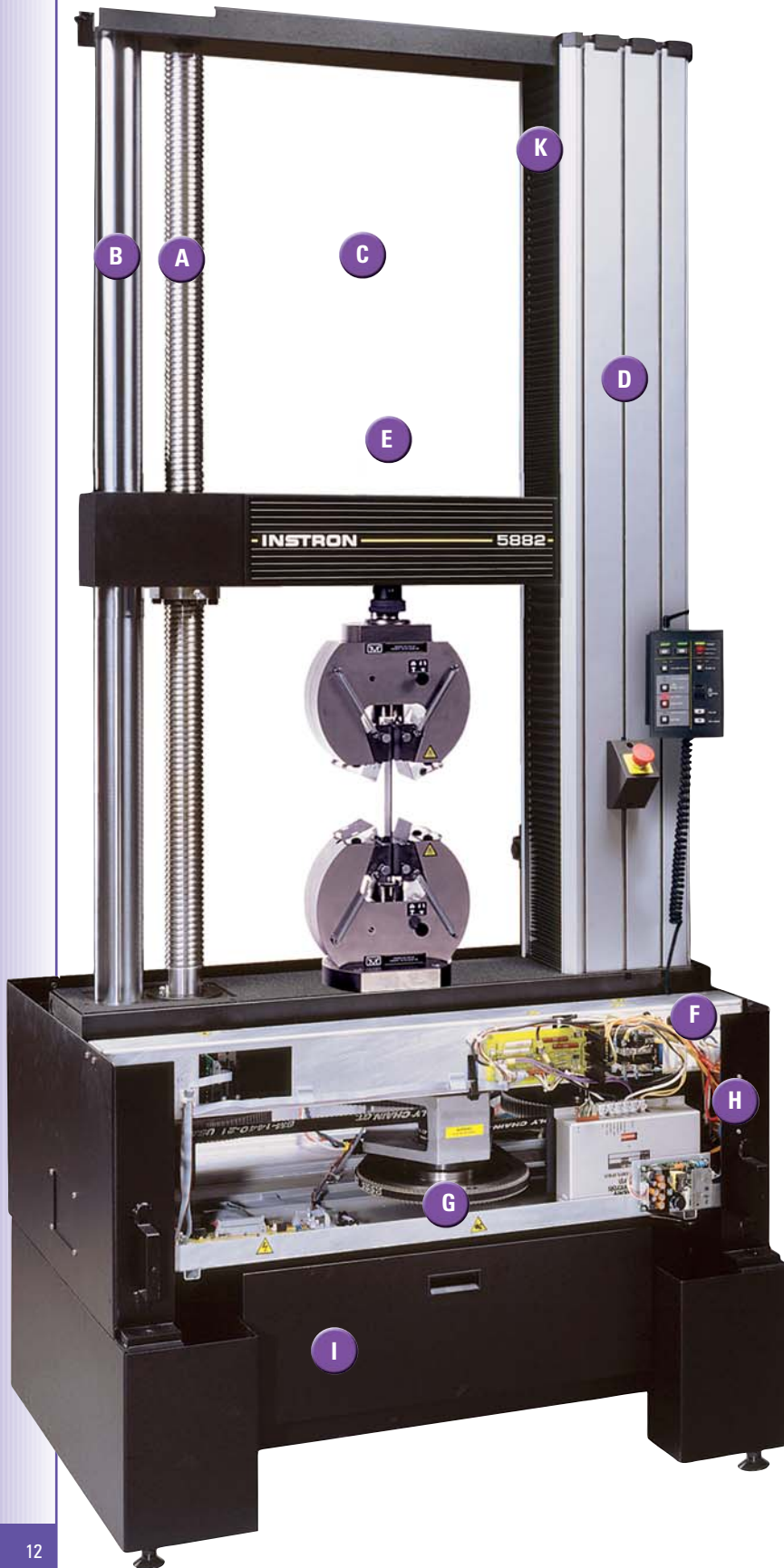

- A** Pre-loaded ball screws and heavy duty bearings assure long life with zero backlash, as well as linear low force and through-zero performance. The result is accurate and repeatable measurements that truly represent the specimen characteristics rather than load frame deficiencies.
- B** Robust guidance columns increase lateral stiffness and ensure linear crosshead travel. This results in accurate crosshead alignment, reducing variability in measurement data and producing better overall accuracy.
- C** Optional second test space allows mounting the load cell in a stationary position. This eliminates transient load output sometimes seen on low force load cells during initial crosshead acceleration.
- D** Easy-to-clean aluminum column covers with chamfered corners to facilitate access to the test area. Patented T-slots are built in for simple, convenient attachment and positioning of testing accessories.
- E** Drop-through load cell mounting on most models for rapid changes, a larger vertical test space and better load string alignment.
- F** High torque DC servo-motor with digital closed-loop position controller for more accurate crosshead speed control, rapid acceleration and full speed performance over a wider load range.
- G** Superior no-clutch design for better reliability, less maintenance and improved load/speed performance.

H Easy to service. All serviceable areas can be reached without tilting, lifting or moving the frame. All cable connections are accessible even when the frame is backed up against a wall.

I Optional floor stand with storage drawer.

J Dual action over-travel limits on all frames provide the highest level of safety and meet all international standards.

K Fully protected lead screw covers provide longer life and greater operator protection.

L Storage areas for specimens, pins, clips and other small items.

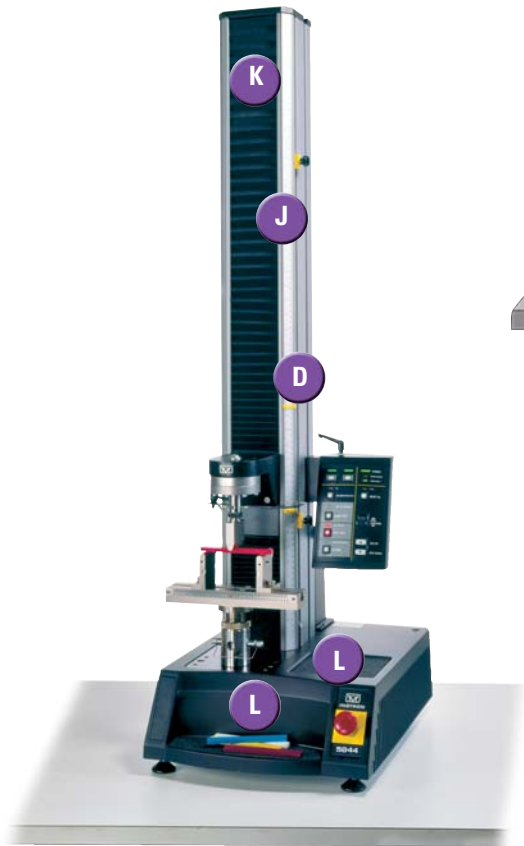
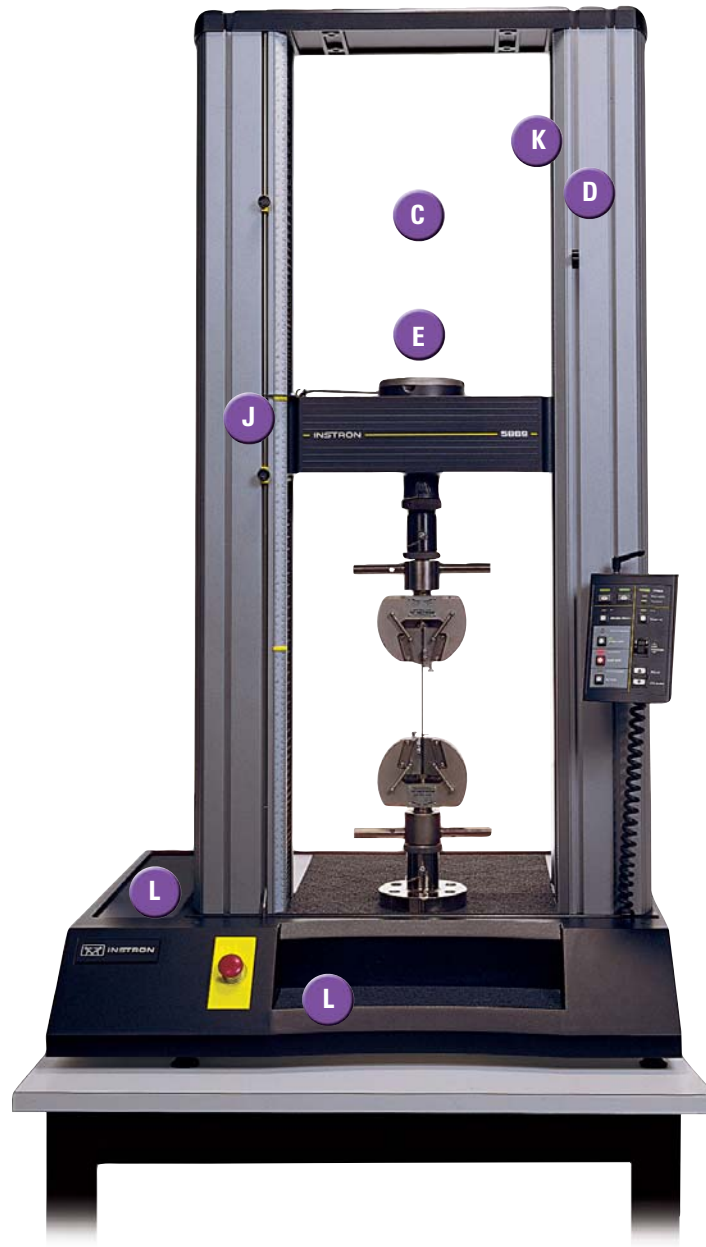

Optional Frames

A range of load frame options provides even greater applications coverage to the 5800 Series. Extra wide frames allow testing on components and finished articles as diverse as automotive parts and beds. High-elongation elastomers, cables and pipes can be accommodated by a range of extra height options. A dual test space option is available on most models to allow different fixture setups to remain permanently installed for enhanced productivity. It also allows the load cell to be installed in a stationary crosshead in low force applications, such as fiber testing.



▲ Extra wide frame ideal for testing large components



▲ Dual test space reducing setup time

Accessories

Instron® offers an extensive selection of accessories, including grips, fixtures, baths and chambers that are easily adapted to any test frame and are guaranteed to fulfill almost any testing requirement. In some instances, our standard offerings do not accommodate the variability of specimens or testing requirements. Through our wealth of testing experience and engineering expertise, we specialize in developing unique application-centric solutions to meet these needs.

Grips

- Lever action fiber grips
- Cord and yarn grips
- Wedge action grips
- Hydraulic grips
- Pneumatic grips

Special Purpose Fixtures

- Friction testing fixtures
- Peel testing fixtures
- Flexure fixtures
- Compression fixtures
- T-slot tables

Extensometry

- Video extensometer
- High Resolution Digital (HRD) automatic extensometers
- Clip-on strain gauge extensometers
- Elastomeric long travel extensometers

Baths and Chambers

- Temperature controlled and circulating saline baths
- High and low temperature environmental chambers
- High and low temperature accessories

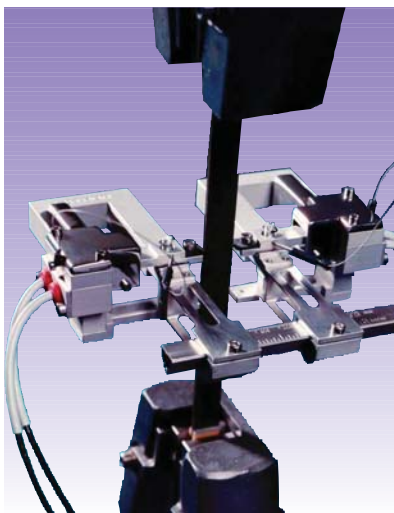

▲ Biaxial extensometer for Poisson's ratio

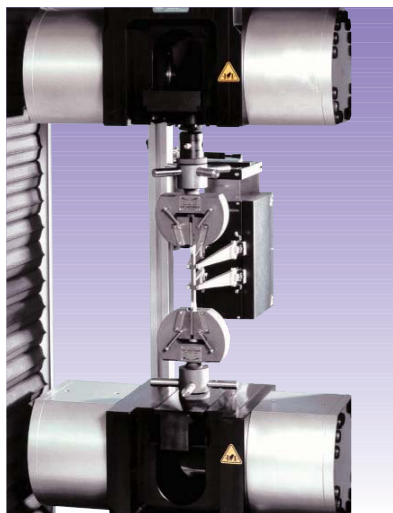

▲ Digital Metals Automatic Extensometer



▲ Environmental chamber for elevated or low temperature testing

Specifications

		Single Column Table Top Models			Twin Column Table Top Models					Floor Standing Models			
		5842	5843	5844	5864	5865	5866	5867	5869	5881	5882	5884	5885H
Load Capacity	kN	0.5	1	2	2	5	10	30	50	50	100	150	250
	kgf	50	100	200	200	500	1000	3000	5000	5000	10000	15000	25000
	lbf	112.5	225	450	450	1125	2250	6750	11250	11250	22500	33750	56200
Maximum Speed	mm/min	1000	1000	1000	2500	1000	500	500	500	1000	500	750	500
	in/min	40	40	40	100	40	20	20	20	40	20	30	20
Minimum Speed	mm/min	0.05	0.05	0.05	0.005	0.001	0.001	0.001	0.001	0.001	0.001	0.001	0.001
	in/min	0.002	0.002	0.002	0.0002	0.00004	0.00004	0.00004	0.00004	0.00004	0.00004	0.00004	0.00004
Maximum Force at Full Speed	kN	0.5	1	2	1	5	10	30	25*	35	75	110	100
	lb	112.5	225	450	225	1125	2250	6750	5620	7870	16860	24730	22500
Maximum Speed at Full Load	mm/min	1000	1000	1000	1000	1000	500	500	250**	500	250	375	200
	in/min	40	40	40	40	40	20	20	10	20	10	15	8
Return Speed	mm/min	1500	1500	1500	2500	1200	600	600	500	1000	600	800	500
	in/min	60	60	60	100	48	24	24	20	40	24	32	20
Position Control Resolution	μm	0.156	0.156	0.208	0.236	0.118	0.057	0.054	0.063	0.100	0.060	0.075	0.060
	μin	6.1	6.1	8.2	9.3	4.6	2.2	2.1	2.5	3.9	2.4	2.9	2.4
Total Crosshead Travel	mm	500	917	917	1135	1135	1135	1135	1135	1235	1235	1180	1180
	in	19.7	36.1	36.1	44.6	44.6	44.6	44.6	44.6	48.6	48.6	46.5	46.5
Total Vertical Test Space <small>(Note 5)</small>	mm	659	1076	1076	1249	1249	1249	1205	1205	1309	1309	1256	1256
	in	25.9	42.4	42.4	49.2	49.2	49.2	47.4	47.4	51.5	51.5	49.4	49.4
Depth Daylight	mm	100	100	100	NA	NA	NA	NA	NA	NA	NA	NA	NA
	in	3.9	3.9	3.9	NA	NA	NA	NA	NA	NA	NA	NA	NA
Space Between Columns	mm	NA	NA	NA	420	420	420	420	420	575	575	575	575
	in	NA	NA	NA	16.5	16.5	16.5	16.5	16.5	22.6	22.6	22.6	22.6
Height <small>(Note 6)</small>	mm	875	1275	1275	1597	1597	1597	1597	1597	2092	2092	2092	2092
	in	34.4	50.2	50.2	62.9	62.9	62.9	62.9	62.9	82.4	82.4	82.4	82.4
Width	mm	375	375	375	909	909	909	909	909	1300	1300	1300	1300
	in	14.75	14.75	14.75	35.8	35.8	35.8	35.8	35.8	51.2	51.2	51.2	51.2
Depth	mm	500	500	500	700	700	700	700	700	756	756	756	756
	in	19.7	19.7	19.7	27.5	27.5	27.5	27.5	27.5	29.8	29.8	29.8	29.8
Weight	kg	32	37	37	136	136	136	182	240	862	862	952	952
	lb	70	80	80	300	300	300	400	530	1900	1900	2100	2100
Maximum Power Requirement	VA	225	225	400	300	300	300	600	700	1400	1400	2800	2850

Common Specifications:

5800 Free standing Controller Dimensions: Height: 500 mm (19.7 in), Width: 135 mm (5.31 in), Depth: 440 mm (17.3 in), Weight: 13.5 kg (30 lb)

Position Measurement Accuracy: ±0.02 mm or 0.05% of displacement (whichever is greater)

Crosshead Speed Accuracy (Zero or constant load): ±0.1% of set speed

Load Measurement Accuracy: ±0.4% of reading down to 1/100 of load cell capacity, ±0.5% of reading down to 1/500 of load cell capacity

Strain Measurement Accuracy: ±0.5% of reading down to 1/50 of full range with ASTM E 83 class B or ISO 9513 class 0.5 extensometer

Single Phase Voltage: 100, 120, 220, or 240 VAC ±10%, 47 to 63 Hz. Power supply must be free of spikes, surges or sags exceeding 10% of the average voltage.

Operating Temperature: +10 to +38 °C (+50 to +100 °F)

Storage Temperature: -40 to +66 °C (-40 to +150 °F)

Humidity Range: +10% to +90%, non-condensing

Atmosphere: Designed for use under normal laboratory conditions. Protective measures may be required if excessive dust, corrosive fumes, electromagnetic field or hazardous conditions are encountered.

Notes:

- Load weighing system meets or surpasses the following standards: ASTM E4, BS 1610, DIN 51221, ISO 7500-1, EN 10002-2 and AFNOR A03-501.
Instron® recommends that systems are verified on site at the time of installation as required by ASTM E 4 (par. 20.3) and ISO 7500-1 (section 9) standards.
- Strain measurement system meets or surpasses the following standards: ASTM E 83, BS 3846, ISO 9513, EN 10002-4.
- Extra high or wide load frames and extra high or low speed drive systems are also available. Contact your nearest Instron office for details.
- These systems conform to all relevant European standards and carry a CE mark.
- Total vertical test space is the distance from the top surface of the base platen to the bottom surface of the moving crosshead, excluding load cell, grips and fixtures.
- Add 295 mm (11.6 in) to 5881, 5882, 5884 and 5885H heights when the optional 2910-061 load frame support base/extension is included.

The above specifications were developed in accordance with Instron's standard procedures and are subject to change without notice.

* 50 kN (11250 lb) with line voltage of 220 V or 240 V. ** 500 mm/min (20 in/min) with line voltage of 220 V or 240 V.



For information on Instron® products and services call your local worldwide sales, service and technical support offices:

Corporate Headquarters

Instron Corporation
825 University Avenue
Norwood, MA 02062-2643 USA
Tel: +1 800 564 8378
+1 781 575 5000
Fax: +1 781 575 5725

European Headquarters

Instron
Coronation Road
High Wycombe, Bucks
HP12 3SY United Kingdom
Tel: +44 1494 464646
Fax: +44 1494 456814

Industrial Products Group

900 Liberty Street
Grove City, PA 16127-9005 USA
Tel: +1 800 726 8378
+1 724 458 9610
Fax: +1 724 458 9614

USA

North America IMT Sales and Service Center

Sales Tel: +1 800 564 8378
Service and Technical Support Tel: +1 800 473 7838

North America IST Sales and Service Center

Sales and Service Tel: +1 248 553 4630

CANADA

Ontario Tel: +1 905 333 9123
+1 800 461 9123

SOUTH AMERICA, CENTRAL AMERICA, MEXICO AND CARIBBEAN

Brazil
Sao Paulo Tel: +55 11 4689 5480

Caribbean, Mexico, South America and Central America
Norwood Tel: +1 781 575 5000

EUROPE

United Kingdom, Ireland and Nordic

High Wycombe Tel: +44 1494 456815

Benelux

Edegem Tel: +32 3 454 0304

France

Paris Tel: +33 1 39 30 66 30

Switzerland

Zurich Tel: 0800 561 550

Germany and Austria

Darmstadt Tel: +49 6151 3917 444

Italy

Milan Tel: +39 02 390 9101

Spain and Portugal

Barcelona Tel: +34 93 594 7560

ASIA PACIFIC

Australia

Melbourne Tel: +61 3 9720 3477

China

Beijing Tel: +86 10 6847 0012
Shanghai Tel: +86 21 6215 8568

India

Chennai Tel: +91 44 2 829 3888

Japan

Tokyo Tel: +81 44 853 8520

Korea

Seoul Tel: +82 2 552 2311/5

Singapore

Tel: +65 6774 3188

Taiwan

Hsinchu Tel: +886 35 722 155/6

Thailand

Bangkok Tel: +66 2 513 8751/52



Instron is a registered trademark of Instron Corporation.

Other names, logos, icons and marks identifying Instron products and services referenced herein are trademarks of Instron Corporation and may not be used without the prior written permission of Instron.

Other product and company names listed are trademarks or trade names of their respective companies.

Copyright © 2006 Instron Corporation. All rights reserved.

All of the specifications shown in this brochure are subject to change without notice.

www.instron.com

WB1132C